



LONGi Solar Module Packaging Instruction

For Hi-MO 6, LR5-54xx-xxx with Frame

V01

Notes:

This introduction is only for the designated LONGi Solar Module Packaging.

LONGi Solar reserves the right to make changes to the packaging specification without prior notice.

Compiled according to the <LGiLE-T-PRD-061>

longi.com/en/

LONGi Solar Technology Co., Ltd.

No. 8369 Shangyuan Road, Caotan Eco-Industrial Zone, Xi'an, 710021, China.

Tel: + 86-29-85767999

Part A. Basic Information List



Series Name	Module		Pallet			20GP Container		40HQ Container	
	Type	Dimension (mm)	Module QTY	Weight* (kg)	Dimension* L×W×H(mm)	Pallet QTY	Total module QTY	Pallet QTY	Total module QTY
Hi-MO 6	LR5-54HTH	1722×1134×30	36	789	1767×1130×1245	6	216	26	936
	LR5-54HTD	1722×1134×30	36	789	1767×1130×1245	6	216	26	936

*Only for reference.

Part B. Container Stacking Solutions

	Pallet QTY	Module QTY
20GP	6	216

	Pallet QTY	Module QTY
40HQ	26	936

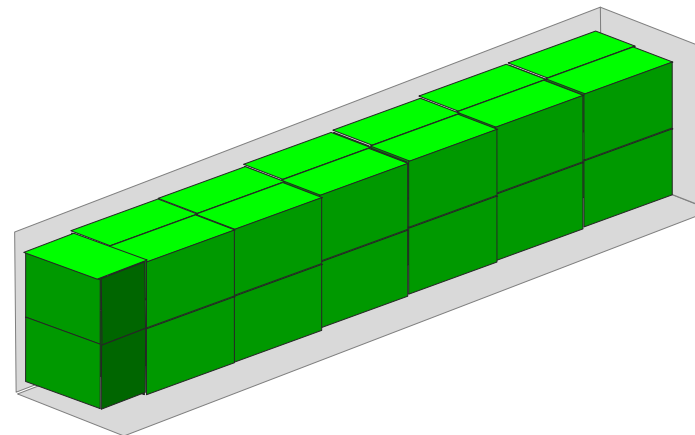
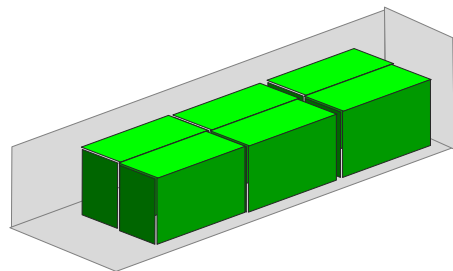

Part B. Container Stacking Solutions

The follow pictures of module and package material are only for reference to understand the package process in general.



Step 1 Prepare the pallet.

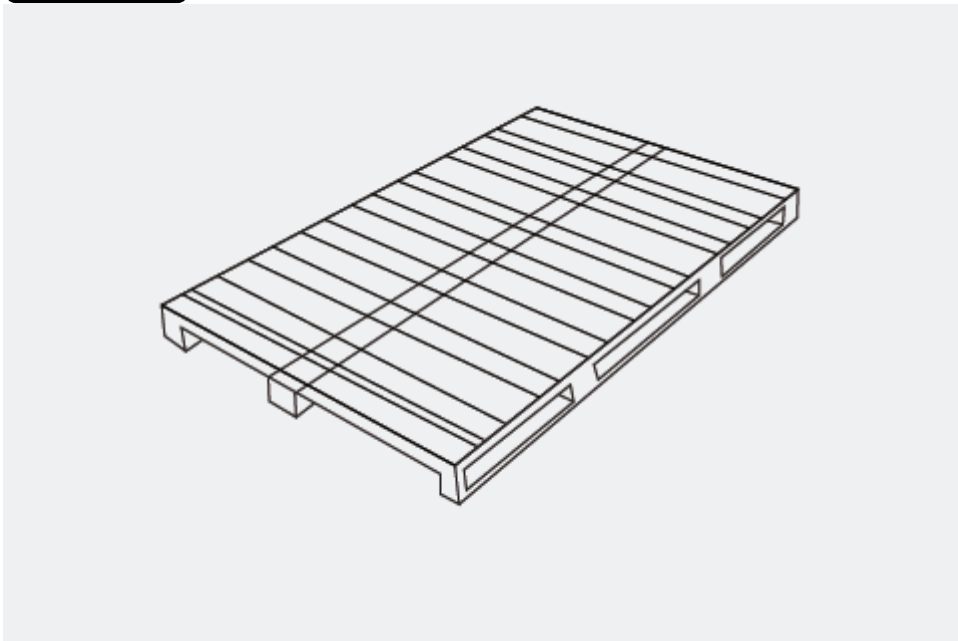

Step 2 Cover a carton bottom panel.

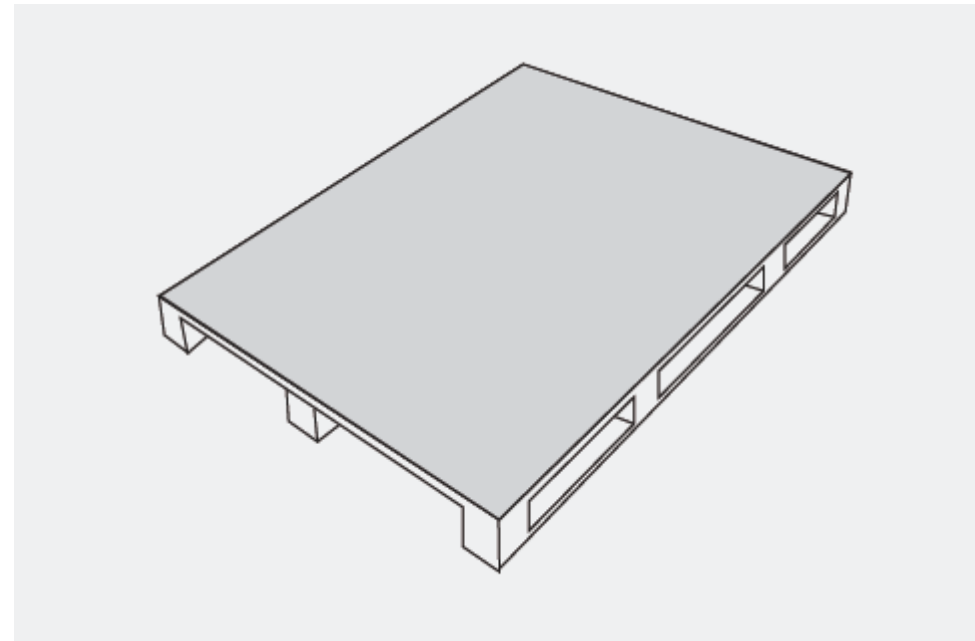

Step 3 Put on the four corner protectors for modules.

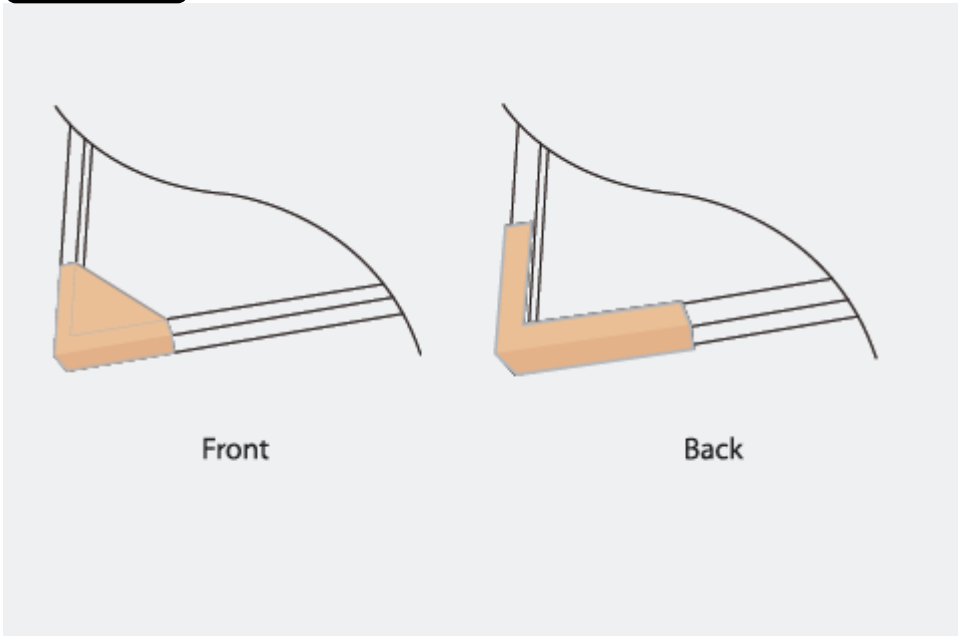

Step 4 Place the first module on the pallet vertically, with the backside upon a supporter.

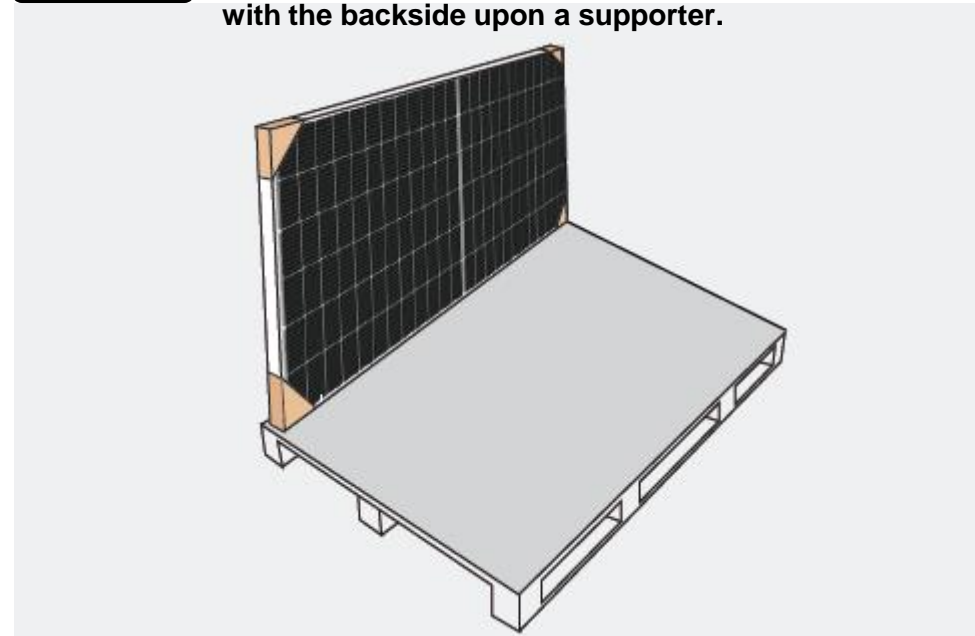

Part B. Container Stacking Solutions

The follow pictures of module and package material are only for reference to understand the package process in general.



Step 5

Place subsequent modules one by one in the same side & direction on the pallet vertically.

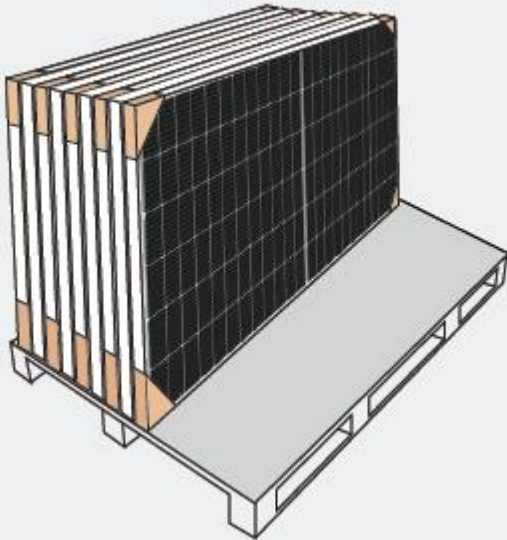

Step 6

Place the last module on the opposite side (backsheet outside). Then place two long corner protectors, fasten the modules with 4 strapping bands.

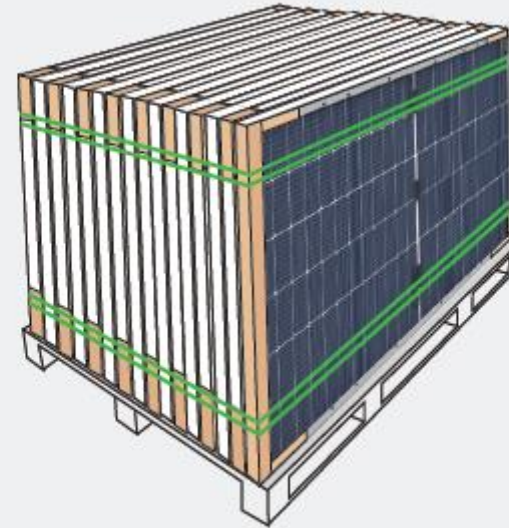

Step 7

Fasten the modules with more strapping bands.

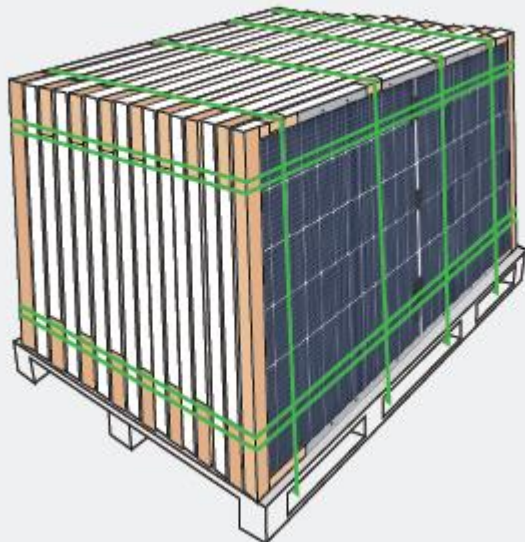

Step 8

Place the cardboard box, Stick the tape for anti-dumping.



Part B. Container Stacking Solutions

The follow pictures of module and package material are only for reference to understand the package process in general.



Step 9

Cover the lid, and stick the shipping list and other document according to customer requirement.

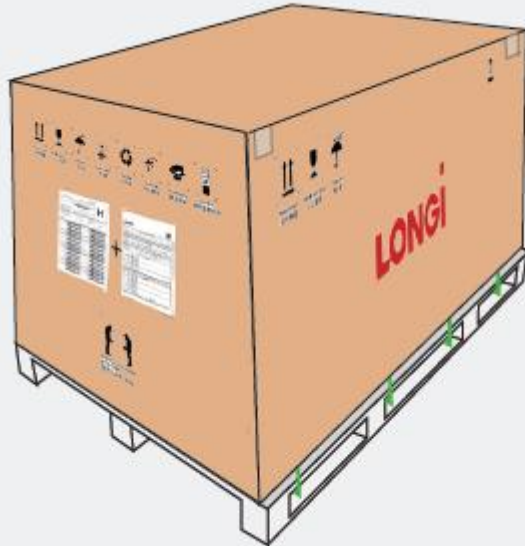

Step 10

Fix two strapping bands around the box, and cover 2 lays wrap film outside the box.

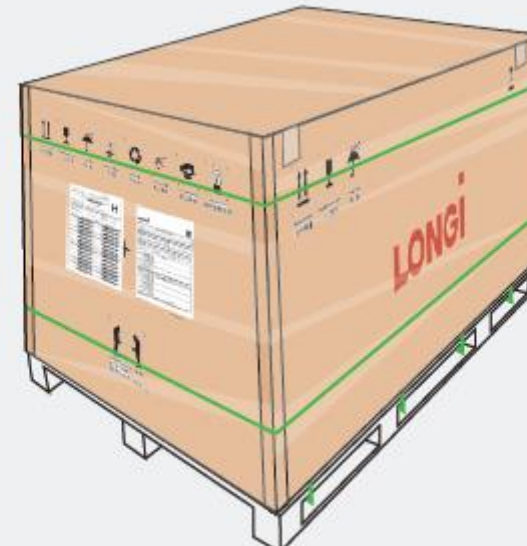

Step 11

Fix the rest of strapping bands around the box.

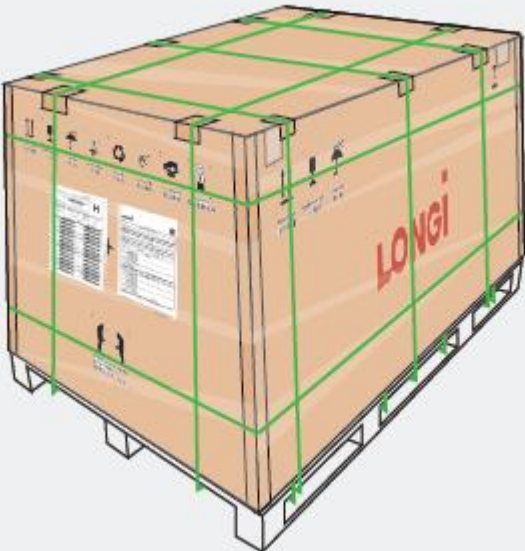

Step 12

Pile up pallets, but no more than 2 layers. Stack pallets in container and fix the outermost row with straps and in case of slipping.

