

HES INSTALLATION MANUAL (IEC)

Issued on Jan. 26th, 2026 (Version1.0)

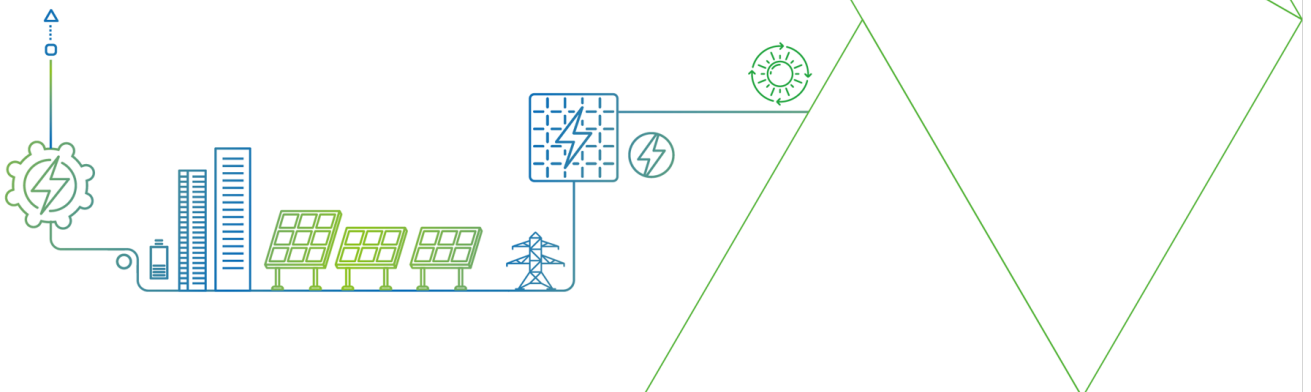

A Reliable Partner for Your Solar Business
PV Total Solution Provider



HJT PV MODULE INSTALLATION MANUAL

Module structure	Module type	
Dual glass Modules	HiT-TxxxNJ	HiT-HxxxCH
	HiT-TxxxNI	HiT-HxxxCH-ZB
	HiT-TxxxNF	HiT-HxxxCF-BF
	HiT-TxxxGH	HiT-HxxxCF-BF(ZB)
	HiT-TxxxCH	HiT-HxxxCE-BF
	HiT-TxxxNI-FS	HiT-HxxxCE-BF(ZB)
		HiT-HxxxNI
		HiT-HxxxGH

Catalogue

1	Basic information-----	4
1.1	Overview-----	4
1.2	Disclaimer-----	4
1.3	Warnings-----	5
1.3.1	Precautions-----	5
1.3.2	Prohibited items-----	6
1.3.3	Other matters-----	6
2	Installation-----	7
2.1	Normal requirements-----	7
2.2	Installation safety-----	8
2.3	Installation condition selection-----	9
2.3.1	Climatic conditions-----	9
2.3.2	Installation site-----	9
2.3.3	Selection of tilt angle-----	10
2.4	Installation method-----	11
2.4.1	Note-----	11
2.4.2	Bolt mounting-----	12
2.4.3	Clamp mounting-----	12
3	Wiring and connections-----	14
3.1	Correct electrical wiring-----	14
3.2	Cable wires and wiring-----	16
3.3	Connector-----	17
3.4	Bypass diode-----	17
3.5	Installation method-----	18
3.5.1	Bolt mounting-----	18
3.5.2	Clamp mounting-----	19
3.5.3	Enhanced mounting-----	21
3.5.4	Cabling method-----	22
4	Maintenance and care-----	24
4.1	Cleaning of PV module-----	24
4.2	Maintenance of PV module-----	24
4.3	Replacement of PV module-----	25
4.4	Inspection of PV junction box and cables-----	25

1 Basic information

1.1 Overview

➤ First of all, thank you for choosing to use the solar PV module products (hereinafter referred to as "module") of HD HYUNDAI ENERGY SOLUTIONS. In order to correctly install and obtain stable power output, you must read and understand all installation instructions before installing, wiring and maintaining the module.

➤ Please remember that you are using a power generation product, so in order to avoid accidents, you need to take appropriate safety measures.

➤ Protection class of modules: Class II (IEC61730:2023). (IEC61730:2016).

➤ Application level of modules: A class (IEC61730:2004).

1.2 Disclaimer

➤ As the conditions for the use of this manual and the installation, operation, use and maintenance of the components are beyond the control of First of all, thank you for choosing to use the solar PV module products (hereinafter referred to as "module") of HD HYUNDAI ENERGY SOLUTIONS shall not be liable for any loss, damage or expense arising from the installation, operation, use or maintenance

➤ HD HYUNDAI ENERGY SOLUTIONS shall not be liable for any infringement of patent and third-party rights caused by the use of the module products. The Customer is not authorized to use any patent or patent rights, whether express or implied, by using the products of HD HYUNDAI ENERGY SOLUTIONS.

➤ The information in this manual is based on the reliable knowledge and experience of HD HYUNDAI ENERGY SOLUTIONS. However, this information and related recommendations, including but not limited to the product specifications mentioned above, do not constitute any warranty, whether express or implied HD HYUNDAI ENERGY SOLUTIONS reserves the right to modify the manual, module products, specifications, or product information without prior notice.

1.3 Warnings

1.3.1 Precautions

- When the module is exposed to sunlight or other light sources, a direct current is generated in the module. Improper contact with the charged part of the module (such as terminals) can lead to the risk of burns, sparks and electric shocks.

- The front glass of the module has the function of protecting the module. The damaged module will lead to electrical safety risks (electric shock or fire). Such modules cannot be repaired and should be removed and replaced immediately.

- Broken back glass (Bifacial PV modules) can also cause electrical safety problems, and like monofacial modules, broken glass cannot be repaired and must be disconnected and replaced immediately.(Note: The nameplate is posted on the rear side of the module.)

- The parameter table is based on standard test conditions (irradiance 1000W/m², module temperature 25°C, AM1.5). The current and voltage generated by the modules under different environmental conditions may differ from those listed in the table. Therefore, when determining the rated voltage, cable capacity, fuse capacity, controller capacity, and other output power-related parameters for other modules of the PV power generation system, refer to IEC 61730, multiply a factor of 1.25 of the short-circuit current and open-circuit voltage values on the module nameplate as a reference values, and consult your inverter/controller supplier for system configuration design. For safety factor selection criteria beyond 1.25, please consult IEC 62548.

- During all transportation, please ensure that the transportation tool is stable and the modules will not be subjected to large vibrations, otherwise the modules may be damaged or the hidden cracks of the cells in the modules may be caused.

- When the load is working, do not disconnect the connection of the module without authorization. if you need to disconnect the connector, you must first turn off the DC and AC converters or disconnect main switch of the combiner box.

- When the battery energy storage system is connected to the PV system, the battery must be installed correctly to protect the operation of the system and ensure user safety. please follow the manufacturer's installation instructions and operational and maintenance recommendations.

1.3.2 Prohibited items

- Do not load excessive force or objects on the surface of the module, do not impact, do not twist the frame of the module, which may damage the cell or cause hidden cracks in the cell.
- Modules are prohibited from being used as a substitute or partial replacement for roofing and wall materials.
- It is forbidden to dismantle any parts of the solar cell modules provided by HD HYUNDAI ENERGY SOLUTIONS without permission.
- Do not lift the module by pulling junction box or cables.
- Modules (glass, junction box, connector, etc.) are prohibited from long-term exposure to sulfur-containing, strong acid, strong alkali and other corrosive environments, and contact with organic solvents that can destroy the front glass anti-reflection coating or junction box and back sheet polymer.
- The junction box must meet the requirements of IP68 (IEC60529) and should avoid direct sunlight and water immersion. the connector should meet the requirements of IP68 (IEC60529) after connection, but long-term using under water is prohibited.
- Do not contact the junction box with oily substances, organic solvents, other corrosive materials and other substances that may cause functional failure (such as alcohol, gasoline, lubricants, rust inhibitors, herbicides, etc.) to avoid damage.
- Do not lift the module by pulling junction box or cables Do not stand or step on the modules, because there is a risk of damaging the modules and injuring the user.
- Do not touch the live parts of the modules directly with bare hands, and use insulated tools for electrical connection.
- Do not use mirrors or lenses to focus sunlight on the modules, and do not expose the back of monofacial modules directly to sunlight.

1.3.3 Other matters

- The module uses anti-reflection film technology. If the color difference is found when observing the module from different angles, this is a normal phenomenon.

- Before the module is installed, rainproof facilities should be added when it is stored in the project site to avoid direct open the air placement.

2 Installation

2.1 Normal requirements

- Ensure that the assembly is installed in a way and bracket system that is strong enough to withstand all predetermined load conditions, which is what the bracket installer must provide.
- The installation bracket system must be inspected and tested by a third-party testing organization with static mechanic analysis capability, using local national, regional or corresponding international standards.
- The mounting bracket of the module must be made of durable, corrosion-resistant and uv-resistant materials.
- The module must be securely fastened to the mounting bracket.
- In areas with large snowfall in winter, a higher installation bracket can be selected to avoid the lowest edge of the module being covered by snow for a long time. In addition, the lowest edge of the module should have a certain height to avoid the module being shaded by weeds and shrubs growing on the ground, so as to reduce the damage caused by windblown debris.
- When the module is installed on a bracket parallel to the roof or wall, the minimum gap between the module frame and the roof or wall is 10cm, which is conducive to air circulation and accelerates the dissipation of condensation water or moisture.
- Before installing modules on the roof, make sure the building is suitable for installation. In addition, any penetration of the roof must be properly sealed to prevent leakage.
- Ensure that the backsheet of the module does not touch the bracket or building structure that can enter the interior of the module, especially when the surface of the module is under external pressure.
- The load described in this manual is the test load. Note: According to the installation requirements of IEC61215-2, when calculating the corresponding maximum design load, a safety factor of 1.5 should be considered.

➤ When installing the modules, pay attention to that the drainage hole of the frame should not be blocked.

2.2 Installation safety

➤ Use appropriate protective equipment when installing modules, including standard insulating safety tools and equipment (hard hats, insulating gloves and rubber insulated shoes, safety belts or belts, ladders, etc.) to avoid direct contact to reduce the risk of electric shock and protect hands from sharp edges.

➤ When installing or repairing the PV system, metal rings, watches and other metal products are prohibited to avoid electric shock danger and damage modules.

➤ When installing, the modules are unpacked. Once the modules are taken out of the packing box, they need to be installed and connected to the inverter in time. If not installed immediately, protective measures should be taken for the connectors (such as adding rubber joint cover, etc.).

➤ Avoid unnecessary touching of modules during installation. The surface and frame of the module may be hot, posing a risk of burns or electric shock. Use standard safety tools and equipment when installing modules.

➤ Installation is prohibited in rainy, snowy or windy weather conditions.

➤ Due to the risk of electric shock, no work shall be carried out when the terminal of the module junction box is wet.

➤ Use insulated and dry tools, do not use wet tools.

➤ The modules connected in the same circuit shall be of the same size, specification and model.

➤ Connect the male and female connectors correctly, check the wiring condition, all connection lines should not be separated from the modules, and the wires should be fixed by means of strapping to avoid the connection lines scratching or squeezing the backsheet of the modules.

➤ Whether the modules are connected to the PV system, during installation or when the modules are exposed to light, do not touch the junction box or connector male and female heads with bare hands, and do not insert any metal objects into the connector.

➤ Keep the connector dry and clean to ensure that it is in good working condition.

- Drilling on the module frame without authorization from HD HYUNDAI ENERGY SOLUTIONS is prohibited, otherwise it may cause corrosion of the module frame or other damage to the module.
- The module will have the effect of thermal expansion and contraction, and the frame will have a certain degree of warping deformation in high and low temperature environment. It is recommended that the interval between adjacent two modules should be greater than or equal to 10mm during installation. the specific interval can be calculated according to the actual installation error and the degree of bracket deformation.
- It is recommended that the force applied between cables and connectors, cables and junction boxes during installation, disassembly, maintenance and any other related processes should not exceed 60N.
- Do not install or use modules near open fire or flammable and explosive objects.

2.3 Installation condition selection

2.3.1 Climatic conditions

- Relative humidity: <85% RH.
- Recommended ambient temperature range: -40°C ~ + 40°C, the working ambient temperature is the monthly average maximum and minimum temperature at the installation site.
- The maximum operating temperature of the module is -40°C ~ 85°C.

2.3.2 Installation site

- In general, modules should be installed in the position where they can receive the most light throughout the year.
- When selecting a site, avoid trees, buildings, or other obstacles that will cast shadows on the modules. Shadows can cause power output loss from the modules, and shadows can still affect the optimal performance and operational safety of the modules, even though bypass diodes have been installed. It is not recommended to operate under permanent shading conditions.
- Do not install modules near open flame or flammable materials.

- Do not install modules in areas that will be submerged in water or exposed to sprinklers or fountains.
- The modules can be installed on land 50 ~ 500m away from the sea, but when installing the modules in the area within this distance range, the connector needs to be protected or dust plug should be added. After removing the dust plug, it must be connected immediately, and other anti-rust measures should be taken to prevent the related parts from rusting.
- When installing modules on the roof, the roof must be covered with at least one layer of fire-resistant material that matches the module's fire resistance rating (please consult your local installer for specific details). To ensure the fire resistance of the modules on the roof, it is recommended to maintain a minimum distance of 10cm between the modules and the roof. This not only helps with ventilation and heat dissipation but also allows for easy access for cleaning, maintenance, and repairs. For PV systems installed on the roof, follow the safety principles of 'from top to bottom' and 'from left to right.' Before installation, comply with local laws and regulations and building fire protection requirements, and use appropriate modules such as fuses, circuit breakers, and grounding connectors.

2.3.3 Selection of tilt angle

- The tilt angle of the module refers to the angle between the surface of the module and the ground plane (Figure 1). The power output is maximum when the module faces the sun.
- In the Northern Hemisphere, it is recommended to position the modules facing south. In the Southern Hemisphere, they should face north. If the tilt angle of the modules deviates from due south (or due north) by 30 degrees, the power output will decrease by approximately 10% to 15%. If the tilt angle deviates by 60 degrees, the power output will decrease by about 20% to 30%. Determine the optimal azimuth for installing the modules based on the latitude and longitude of the installation site.
- It is recommended that the tilt angle of the module should not be less than 10 degrees, so that the surface dust of the module can be easily carried away by rain when it rains, thus reducing the number of cleaning times of the module. At the same time, it is conducive to the drainage of water on the surface of the module, avoiding long-term large amounts of water accumulation on the glass to leave marks, thus affecting the appearance and performance of the module.
- For off-grid solar PV systems, the tilt angle of the modules should be determined based on seasonal and light conditions to maximize power output. Typically, if the module's output can meet the

minimum light intensity requirements of the year, this angle will satisfy the system's annual needs. For grid-connected PV systems, the tilt angle of the modules should be chosen to maximize annual output.

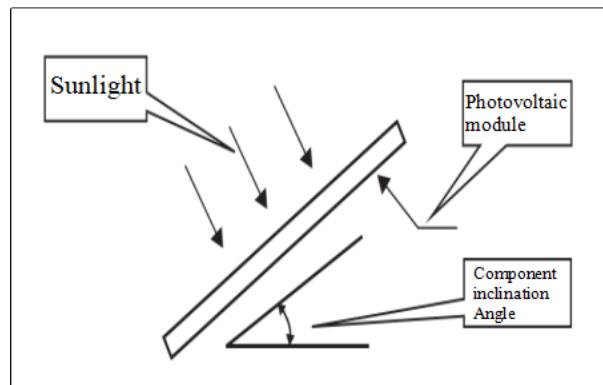

Fig. 1 Module installation angle

2.4 Installation method

➤ The installation of modules can be carried out in the following ways: bolt installation and block pressing.

2.4.1 Note

➤ The module load values listed in this manual are test loads. The installation method is for reference only, and the test results of third-party tests and internal tests of HD HYUNDAI ENERGY SOLUTIONS shall prevail.

➤ HD HYUNDAI ENERGY SOLUTIONS does not provide related safety accessories, and the system installation personnel or trained professionals must be responsible for the design, installation, mechanical load calculation and system safety of the PV system.

➤ Before installation, the following matters should be noted:

- a) Check the appearance of the module for damage. If any dirt or residue remains, clean the module.
- b) Check that the serial number of the module is correct.

➤ The maximum load that can be borne by the front and back of different types of modules depends on the installation method, which can be referred to Table 2 and Table 4. If the environment where the module is installed is snowy and windy, special protection should be taken during the installation of the module to meet the actual requirements.

2.4.2 Bolt mounting

➤ Install the modules on the bracket guide rails using anti-corrosion bolts, elastic washers, and flat washers. The torque should be sufficient to securely fix the modules. For M8 bolts, the recommended torque is 16 to 20 N*m, and for M6 bolts, it is 9 to 12 N*m. If you require a special bracket system or installation method, please confirm the torque values with the bracket supplier again. See Figure 2 for the installation diagram.

➤ The installation holes of the modules are equipped with M8 and M6 bolts. Table 1 lists the bolt sizes corresponding to different sizes of installation holes.

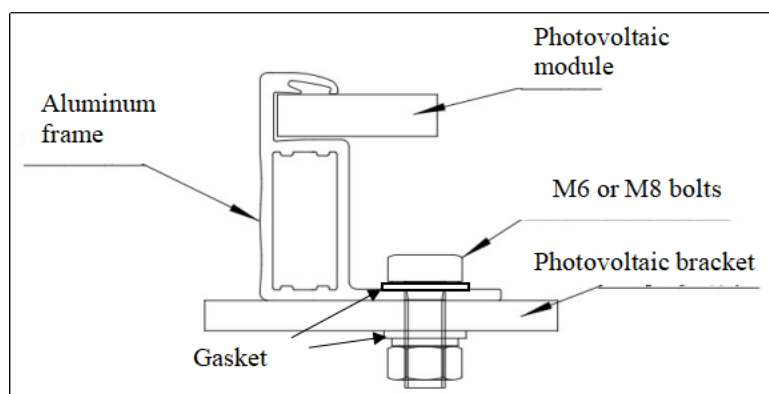

Fig. 2 Bolt mounting diagram

Table 1 Bolt size corresponding to different mounting holes	
mounting hole(mm)	Suggest bolt size
14 x 9	M8
10 x 7	M6

2.4.3 Clamp mounting

The mounting block shall not be in contact with front glass of the modules and shall not deform the frame of the modules. Ensure that the clamps do not cast shadows on the module. Under no circumstances should the frame be altered. When selecting clamp mounting, ensure that there are at least four clamps on each module. The different installation positions of the pressure blocks determine the maximum load capacity of the module. Based on local wind and snow loads, if there is a possibility of excessive load combinations, additional pressure blocks are required to ensure the module has sufficient load-bearing

capacity. The torque applied during clamps mounting should be large enough to securely fix the module (please consult the installer or bracket supplier for specific torque values). As shown in Figure 3, the length and width of the pressure block are denoted by a and b , respectively, and the distance from the installation position of the long side of the pressure block to the edge is denoted by d . Here, a is greater than or equal to 50mm, the contact width between the pressure block and the frame is greater than or equal to 10mm, and the thickness t is greater than or equal to 3mm. It is recommended to use 6005-T6 aluminum alloy for the pressure blocks, with a $Rp0.2$ of 225MPa and a Rm of 265MPa.

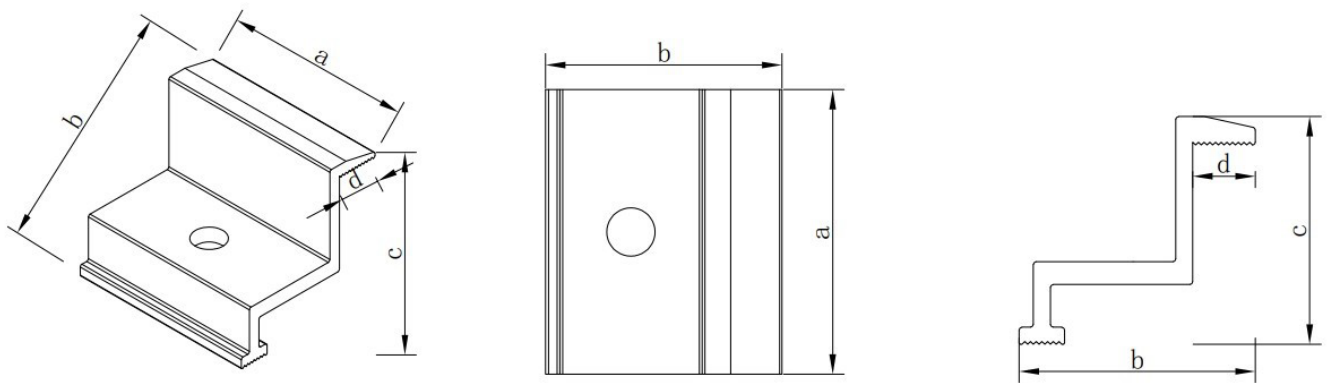

Fig. 3 Schematic diagram of clamp

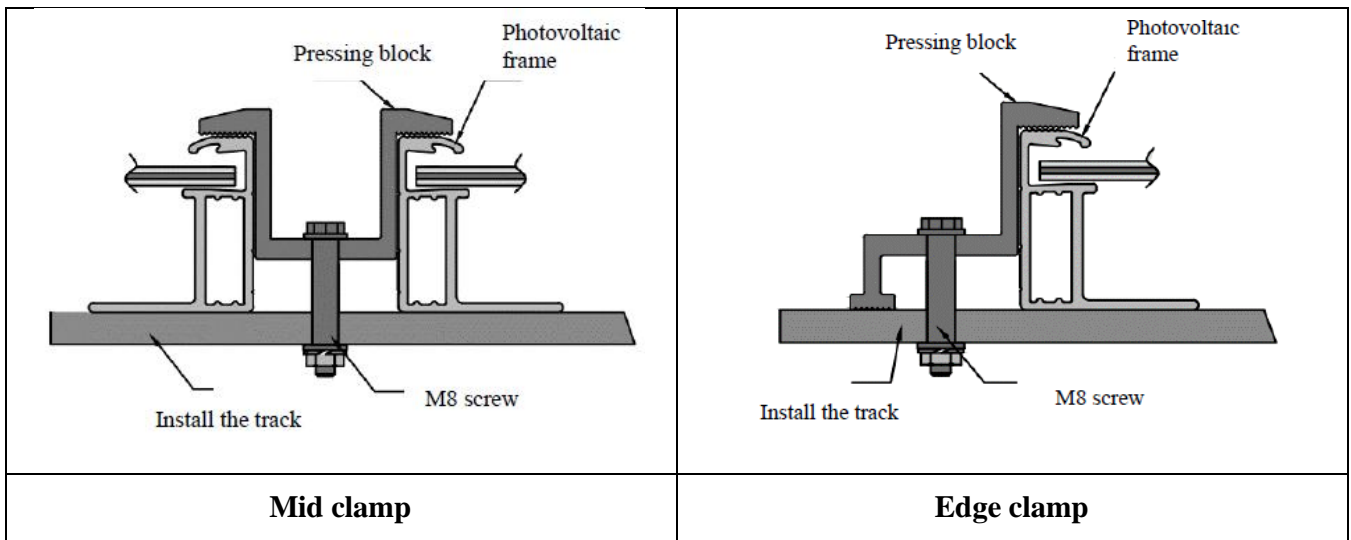

Fig. 4 Schematic diagram of clamp mounting

3 Wiring and connections

3.1 Correct electrical wiring

➤ Check all wiring is correctly connected before starting the system. If the measured open circuit voltage (Voc) and short circuit current (Isc) are not consistent with the provided specifications, there may be a wiring fault.

➤ For PV modules in series, the total voltage equals the sum of individual module voltages; for parallel connections, the total current is the sum of individual module currents. As illustrated in Figure 5, different module types cannot be mixed within a single string.

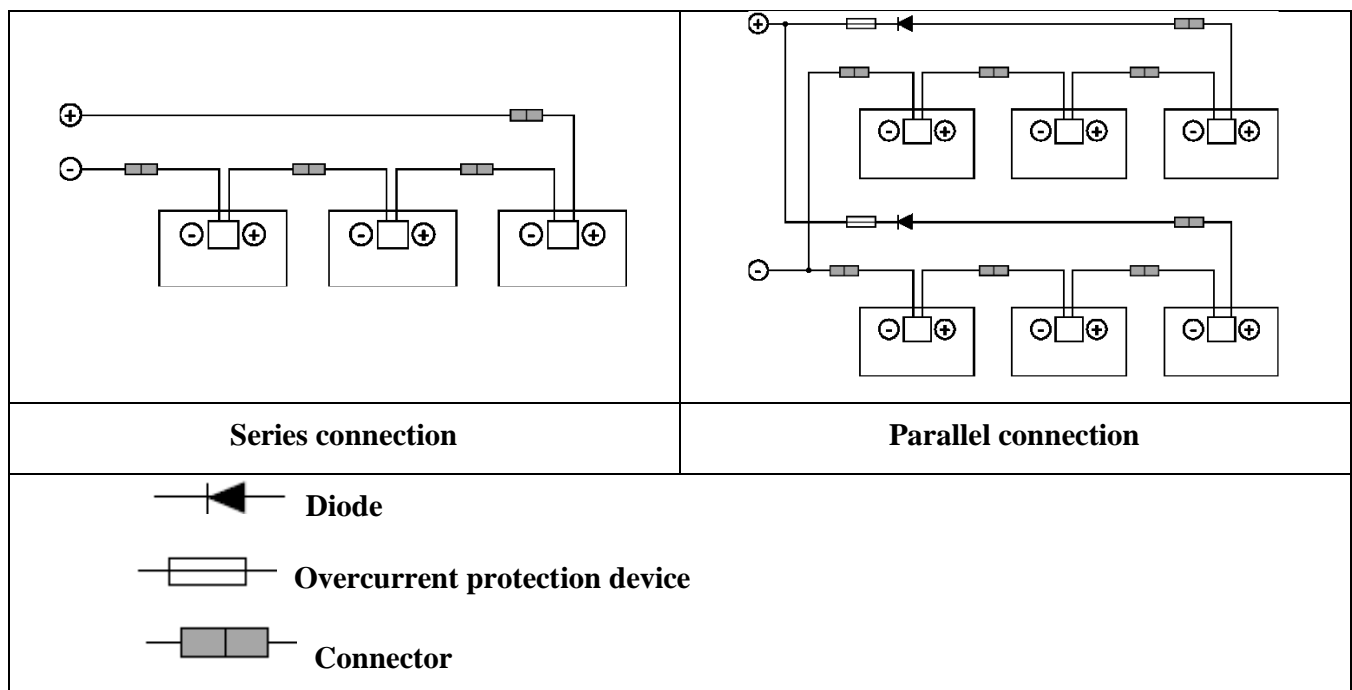

Figure 5 Series/Parallel Circuit Electrical Diagram

➤ When connecting solar panels in series, solar panels with the same current rating must be selected, and the total voltage generated by the series-connected panels should not exceed the system's maximum allowable voltage. The maximum number of series-connected panels is determined by the system design and the inverter's specifications. The maximum number of panels that can be connected in a single series must be calculated according to relevant regulations. The open-circuit voltage of the panels under the expected minimum local temperature conditions must not exceed the maximum system voltage specified for the panels (the maximum system voltage for the panels is DC1000V/DC1500V, depending on the panel model and inverter selected) and other values required by other DC electrical modules.

- The open circuit voltage correction factor can be calculated according to the following formula: $CV_{oc}=1-\beta V_{oc} \times (25-T)$. T is the expected minimum ambient temperature at the installation location of the system, and β (%)/°C is the temperature coefficient of the selected module V_{oc} (see the corresponding module datasheet).
- Modules shall be protected with overcurrent protection devices having identical ratings when reverse currents could exceed the maximum series fuse rating.
- Appropriate protection measures should be taken to prevent moisture and dust from entering the connector before the connecting module to the grid.
- Cables should be fixed to the module frame or mounting rail to avoid shading the back of the module.
- In order to meet the system wiring requirements, for adjacent modules on both sides, the distance between modules should be within 50mm. for adjacent Modules in two rows above and below, the distance between Modules should be within 25mm.
- All modules shall be grounded in accordance with international or local electrical regulations and shall be connected by qualified electricians.
 - a) In the design of PV modules, anodic oxidation corrosion-resistant aluminum alloy frame is used as a rigid support.
 - b) In order to use safely and avoid lightning and static damage to PV modules, the frame of PV modules must be grounded.
 - c) When grounding, the grounding device must be fully in contact with the aluminum alloy interior and penetrate the oxide film on the surface. The following are specific grounding methods, as shown in Figure 6:

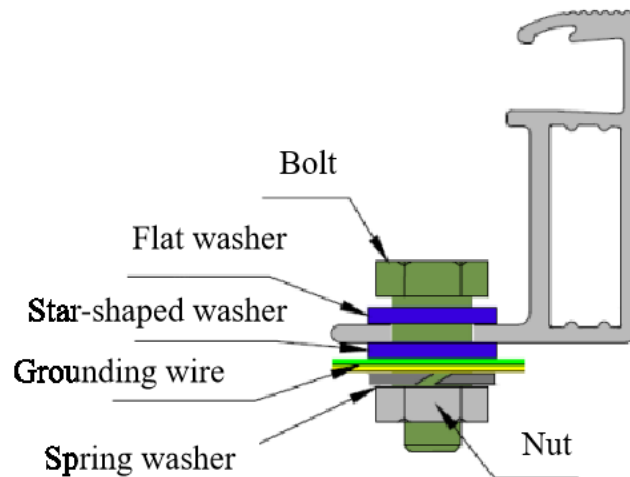

Figure 6 Module connection map

- Use an M5 nut, two M5 retaining rings, an M5 flat washer, an M5 spring washer, an M5 bolt and copper wire to ground the anodized frame through a grounding hole with a diameter of 4~5mm. All nuts, bolts and washers should be M5 type and stainless steel.
- Pass the bolt through the ring gasket and wind the copper wire around the bolt (note: the copper wire should not be in direct contact with the aluminum frame).
- Pass the bolt through the retaining ring and then through the aluminum frame.
- On the other side, pass the spring washer and nut through the bolt and lock it. The tightening torque should be 4 to 5.5 N*m.

➤ Electrical connections shall comply with the relevant local electrical regulations.

3.2 Cable wires and wiring

➤ Open the connector of the control system and connect the cables of the PV array to the combiner box according to the design and local specifications. The cross-sectional area and capacity of the wires must meet the maximum short-circuit current of the PV array (for individual modules, the wire's cross-sectional area should be 4mm², with a rated current exceeding 10A). Otherwise, the cables and connectors may overheat due to excessive current. Note that the upper operating temperature limit for the cable is 90°C.

➤ The length of the cable in the junction box is determined according to the module specification

and customer's design requirements.

- When fixing the cable, it is necessary to avoid mechanical damage to the cable or modules. the minimum bending radius of the cable is 38.4mm, do not bend the cable too much.
- Avoid direct sunlight and water immersion of cables.
- Cable layout must comply with local laws and regulations.

3.3 Connector

- Ensure that the PV junction box is fastened and correctly connected. The PV junction box shall not bear external pressure. The PV junction box shall only be used for circuit connection function, not for opening and closing the circuit.
 - If the PV junction box is not connected with positive and negative, the PV junction box is not waterproof. After the installation of the module, it needs to be connected as soon as possible or take appropriate measures (such as using PV junction box end cap) to avoid water vapor and dust.
 - Do not use lubricants or other unapproved chemicals to clean the PV junction box.
 - Do not connect different types of connectors (brands/models) together. If non-approved connectors or tools (not officially designated by HD HYUNDAI ENERGY SOLUTIONS) are used, or if installation is not performed according to specifications, HD HYUNDAI ENERGY SOLUTIONS will not guarantee the safety or technical consistency of the product.

3.4 Bypass diode

- The PV junction box contains a bypass diode. Incorrect connections between modules can damage the diode, cables, and the PV junction box. When a module develops a hot spot, the diode will activate, preventing the main current from flowing through the hot spot cell, thereby limiting the module's heat generation and performance loss. Note that the bypass diode is not an overcurrent protection device.
 - The PV junction boxes and bypass diodes from different manufacturers cannot be used together. If you need to replace, please consult HD HYUNDAI ENERGY SOLUTIONS.
 - In case of a confirmed or suspected diode failure, please contact HD HYUNDAI ENERGY SOLUTIONS Do not attempt to open the PV junction box of the module yourself.

3.5 Installation method

3.5.1 Bolt mounting

The bolt mounting locations and corresponding load-bearing capacity for the bifacial modules can be found in the following chart.

(Note: All distances and lengths in the table are measured in millimeters (mm), and pressure units are in Pascals (Pa).)

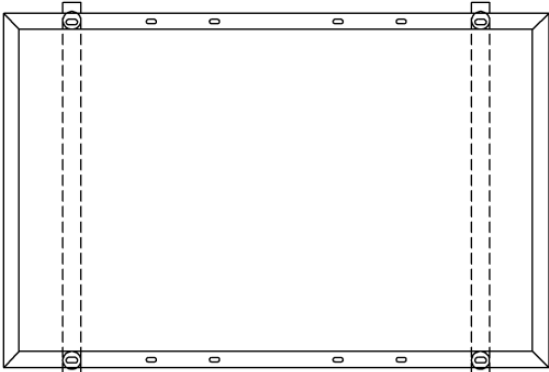
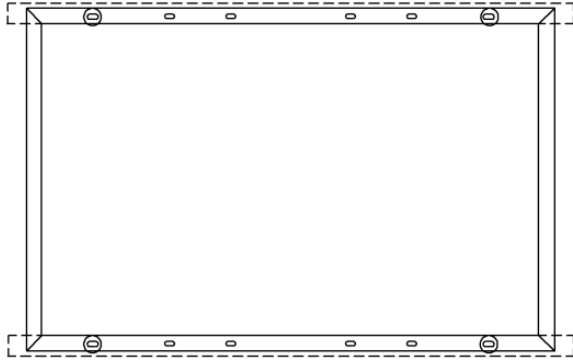
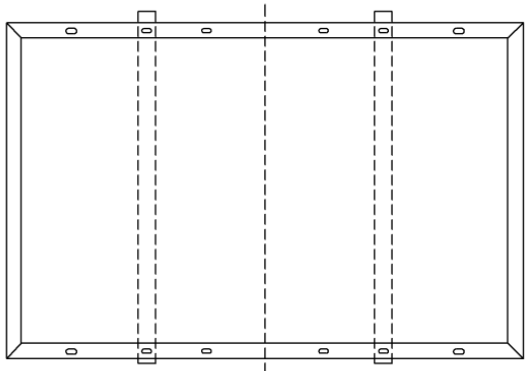
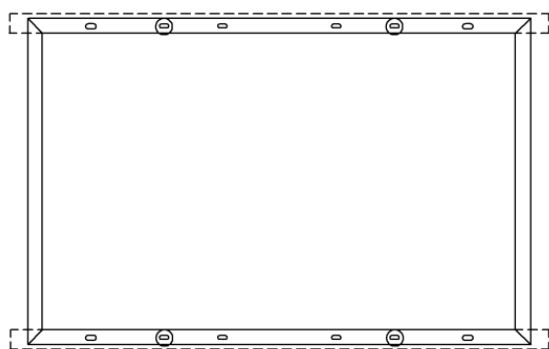
Table 2 Bolt mounting method and corresponding position	
<p>Installation method A Four-hole outer mounting perpendicular to the long frame</p> 	<p>Installation method B Four-hole outer mounting parallel to the long frame</p> 
<p>Installation method C Four-hole inner mounting perpendicular to the long frame</p> 	<p>Installation method D Four-hole inner mounting parallel to the long frame</p> 

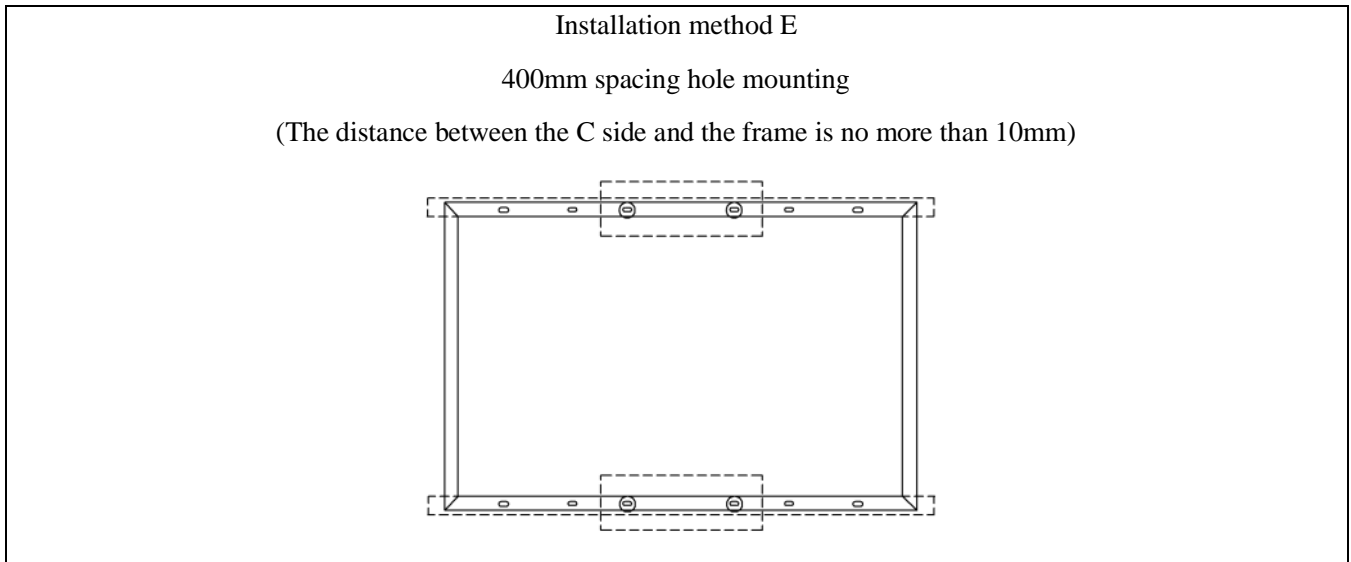

Table 3 Maximum allowable load at designated bolt mounting locations

Installation method Module model	Maximum test load				
	Installation method A	Installation method B	Installation method C	Installation method D	Installation method E
HiT-HxxxCE-BF HiT-HxxxCE-BF(ZB) (1762*1134*30)	+5400/-2400	/	/	/	/
HiT-HxxxCF-BF(ZB) (1961*1134*30)	+5400/-2400	/	/	/	/
HiT-TxxxNI (2278*1134*30)	+5400/-2400	+3600/-2400	/	/	+1600/-1600
HiT-HxxxNI (2278*1134*30)	+5400/-2400	+3600/-2400	/	/	+1600/-1600
HiT-TxxxCH (2382*1134*30)	+5400/-2400	+3600/-2400	/	/	+1600/-1600
HiT-HxxxCH HiT-HxxxCH-ZB (2382*1134*30)	+5400/-2400	+3600/-2400	/	/	+1600/-1600
HiT-TxxxGH (2384*1303*33)	+5400/-2400	+3600/-2400	/	/	/
HiT-HxxxGH (2384*1303*33)	+5400/-2400	+3600/-2400	/	/	/
HiT-TxxxNJ (2465*1134*30)	/	/	+5400/-2400	/	/

3.5.2 Clamp mounting

When selecting the clamp mounting method, ensure that there are at least four clamps on each module. The different installation positions of the clamps will affect the maximum load capacity of the module. Refer to the following chart for details.

Table 4 The installation method and corresponding position of the clamp

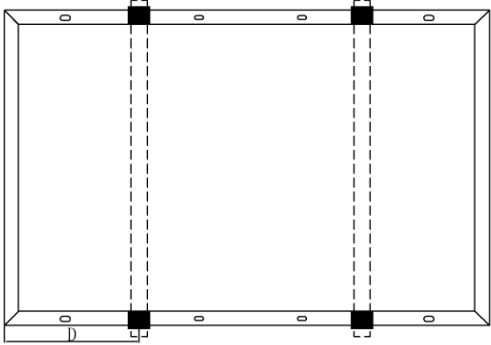
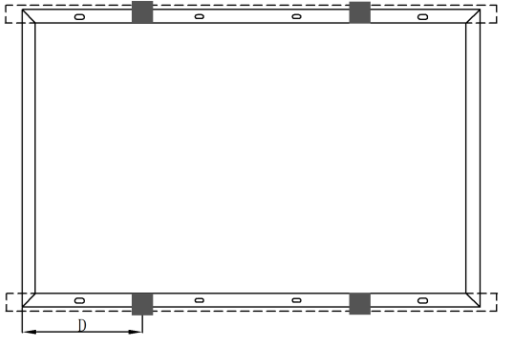
	Installation method F Clamp mounting perpendicular to the long frame	Installation method G Clamp mounting parallel to the long frame
Long side installation		

Installation method Module model	Maximum test load		
	Installation distance D	Installation method F	Installation method G
HiT-HxxxCF-BF HiT-HxxxCE-BF(ZB) (1762*1134*30)	300-350	+5400/-2400	/
HiT-HxxxCF-BF(ZB) (1961*1134*30)	305-405	+5400/-2400/	/
HiT-TxxxNI (2278*1134*30)	520-620	+5400/-2400	+3600/-2400
HiT-HxxxNI (2278*1134*30)	520-620	+5400/-2400	+3600/-2400
HiT-TxxxCH (2382*1134*30)	545-645	+5400/-2400	+3600/-2400
HiT-HxxxCH HiT-HxxxCH-ZB (2382*1134*30)	545-645	+5400/-2400	+3600/-2400
HiT-TxxxGH (2384*1303*33)	545-645	+5400/-2400	+3600/-2400
HiT-HxxxGH (2384*1303*33)	545-645	+5400/-2400	+3600/-2400
HiT-TxxxNJ (2465*1134*30)	565-665	+5400/-2400	/

3.5.3 Enhanced mounting

Table 6 Enhanced mounting method and corresponding position

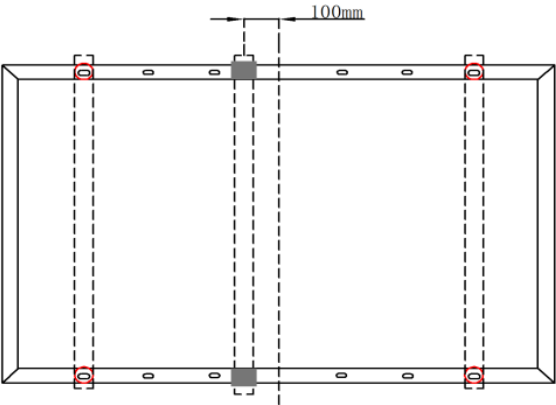
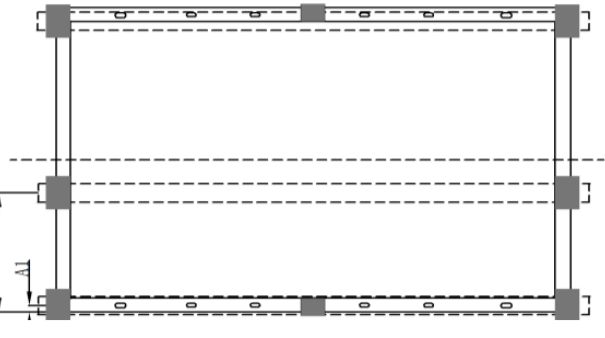
Installation method -K	Installation method -L
<p>Three rail combination mounting, perpendicular to the long frame (Mounting with four holes bolts and intermediate clamp)</p>	<p>Three rail mounting, parallel to the long side (3 clamps on each short side + 1 clamp in the middle of each long side)</p>
	

Installation method Module model	Installation spacing K		Installation spacing L	
	Spacing	Maximum load	Spacing	Maximum load
HiT-TxxxNI (2278*1134*30)	The center of the clamp is 100mm away from the center of the module	+5400Pa/ -5400Pa	A1=20mm±10mm A2=507±10mm	+5400Pa/ -2400Pa
HiT-HxxxNI (2278*1134*30)	The center of the clamp is 100mm away from the center of the module	+5400Pa/ -5400Pa	A1=20mm±10mm A2=507±10mm	+5400Pa/ -2400Pa
HiT-TxxxCH (2382*1134*30)	The center of the clamp is 100mm away from the center of the module	+5400Pa/ -5400Pa	A1=20mm±10mm A2=507±10mm	+5400Pa/ -2400Pa
HiT-HxxxCH HiT-HxxxCH-ZB (2382*1134*30)	The center of the clamp is 100mm away from the center of the module	+5400Pa/ -5400Pa	A1=20mm±10mm A2=507±10mm	+5400Pa/ -5400Pa
HiT-TxxxGH (2384*1303*33)	/	/	/	/
HiT-HxxxGH (2384*1303*33)	/	/	/	/

3.5.4 Cabling method

➤ The cable management scheme shall be reviewed and approved by the EPC contractor, and the required length of cable shall be checked.

➤ After the installation of modules and before the system is connected to the grid, each series should be kept in an open circuit, and appropriate protection measures should be taken to avoid water vapor and dust infiltration.

The recommended wiring method is as follows. Refer to the product data sheet for the length of relevant standard cables.

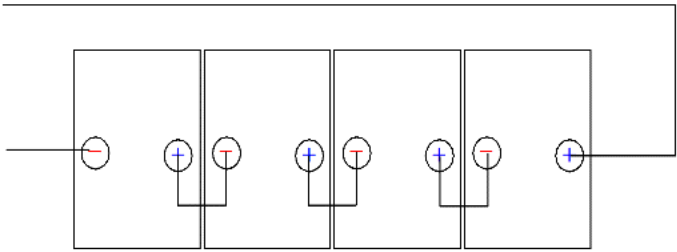
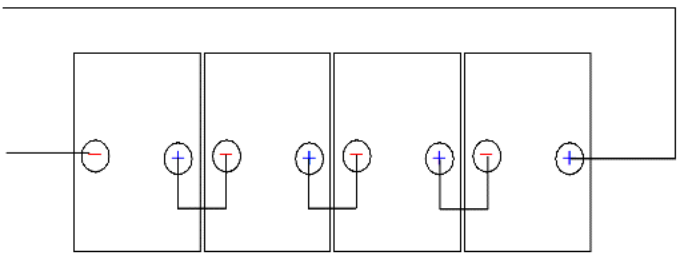
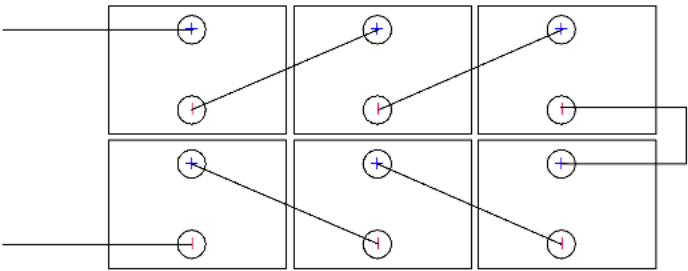
<p>Recommended wiring method</p>	<p>Schematic Diagram</p>
<p>The modules are mounted in portrait orientation</p> <p>Select standard short cable</p>	 <p>Note: The ends of the upper and lower rows need to be connected</p>
<p>The modules are mounted in portrait orientation</p> <p>Select standard short cable</p>	
<p>The modules are mounted in landscape orientation</p> <p>Choose standard long cable or customize</p>	

4 Maintenance and care

In PV power stations, PV modules, as the core power generation units, are devices that directly convert light energy into electrical energy. The performance of these modules significantly impacts the power generation and profitability of the entire station. Therefore, maintaining and cleaning PV modules is crucial to prevent dust accumulation and thermal spots, thereby enhancing their power generation efficiency and extending their service life.

4.1 Cleaning of PV module

Dust and other natural debris, such as bird droppings, can accumulate on the glass surface of module, reducing their output power and potentially causing localized hot spots. Normally, the amount of rainwater is sufficient to keep the glass clean; however, in dusty environments, more frequent cleaning is recommended. When necessary, use a soft, damp sponge or cloth to clean the glass surface, avoiding materials with rough surfaces. Water with high mineral content can leave deposits on the glass, so it is not recommended. It is advised to use neutral water with a pH level between 6.5 and 8.5 for cleaning to prevent damage to the glass coating.

1. Do not use rough and sharp materials for module cleaning.
2. In order to reduce the potential for electric shock or burns, it is recommended that PV module cleaning be performed in the morning or evening when the light is not strong and the module temperature is low, especially in areas with high temperatures.
3. Do not attempt to clean PV modules that have broken glass or exposed wires, which are at risk of electric shock.
4. Do not use chemicals to clean the modules, which may affect the maintenance of the modules and power output. In extreme climate environment, if you need to use chemicals to clean the modules, please contact the after-sales department of HD HYUNDAI ENERGY SOLUTIONS for specific requirements.
5. Clean the back of the module regularly as required. Wear insulating gloves and pay special attention to cables and electrical connections when cleaning the back.

If the glass or backsheet of the PV module is punctured or perforated, do not attempt to clean or handle the module. Such damage poses a severe risk of electric shock and potential fire hazards.

4.2 Maintenance of PV module

➤ It is recommended to carry out regular inspection of the modules. The external problems of the modules can be detected visually, or detailed electrical detection can be carried out after shutting down the system. PV modules use anti-reflection film technology. If color differences are found when observing the

modules from different angles, this is a normal phenomenon.

➤ The module exposed to the sun will produce high voltage. Please pay attention to safety during maintenance and must be carried out by professionals. When repairing the module, please cover the surface of the module with opaque material to prevent electric shock.

➤ Please pay attention to the following matters during maintenance (do not use sharp objects to contact the surface of the module).

1. Check whether the module is blocked and whether the structural system is loose.

2. Whether the module is damaged, such as glass damage, backsheet burn-through, connector aging, whether the grounding wire is well connected, accessory corrosion phenomenon, etc.

3. Check whether the fixing screws between the module and the bracket are loose or damaged, and adjust or repair them in time.

4. Check for corrosion near the cell grid. This corrosion is caused by damage to the packaging material on the surface of the module during installation or transportation, resulting in water vapor penetration into the interior of the module, and check for backsheet damage.

4.3 Replacement of PV module

If the module is damaged, replace the damaged module with the same type of module. Do not touch the live parts of the cable and connector when replacing the module. If you need to replace the connector, when the maintenance personnel open the connector, be sure to confirm that the module is intact, otherwise the connector must be replaced. The damage of the connector can easily lead to leakage.

4.4 Inspection of PV junction box and cables

Conduct regular mechanical and electrical checks to ensure that module connector is clean, connections are reliable, and there is no damage or corrosion. It is recommended that the following preventive maintenance be performed every six months:

➤ Check the sealant of the junction box to ensure that there are no cracks or gaps.

➤ Inspect the modules for aging indicators. Check the rodent damage and material aging in all wiring, as well as for tight connections and corrosion in all connectors. Check if the modules are properly grounded.